

KB818 User's Guide

1. System Composition

The KB818 series is composed of master unit (desk top or wall on), calling buttons, display panels, urgent buttons, alarm lamps, signal collector and computer. The master unit and calling buttons are basic component parts in the calling management system and the others are options.

2. Functional Features

- There are 7-segment light devices and LED indicator in the master unit. The 7-segment LED with 4 digits is used for display calling number (user ID) or current time (hours and minutes). The indicator will switch on when corresponding calling is happened. The master unit can drive 60 calling buttons and can extend to 96.
- The master unit can call any calling button in the system and the calling button can also call the master unit. The calling buttons are managed as 3 levels, urgent, special and normal with calling priorities from higher to lower. Calling priorities determine what calling is taking when more than one calling is pending simultaneously.
- The calling buttons have individual user ID and can set in-circuit any time, they are used to give an alarm, calling and broadcast.
- The display panel with single side or double side large size 7-segment LED is used for display current time or user ID and mount in public area usually.
- The alarm lamps can install on the wall out of the door. It will light on when corresponding calling button is calling for auxiliary indicator.
- Computer management is available.
- Paging system is compatible with this system when computer management is used.
- System self-test can carry out automatically when power on every time.

3. Specification

- Maximum number of calling buttons : 96
- Maximum number of display panels : no limit
- The communication bus distance : 500 meters (with repeater)
- Power supply : 220V \pm 10%, 50Hz
- Power consumption : <30W
- Working condition : temperature -10—40°C, humidity \cong 90%

4. Usage

A) Normal user call

Press the normal calling button down, the green LED switch on. Then the master unit plays music, user ID display and corresponding LED on. This indicates a normal user call. Three operations are chosen, as follows

- 1) Press the normal calling button down again, the green LED switch off, Then the master unit stop music, current time display and corresponding LED off. The user call stop.

- 2) Take the phone underhand up on the master unit within music duration (10 seconds), the normal calling button ring and the red LED switch on. The communication is set up between the master unit and normal calling button. To put underhand down on the master unit or press down the normal calling button again will disconnect the communication. The green LED and red LED will switch off on the normal calling button.
- 3) After 10 seconds, the master unit stops music and comes into waiting status. The master unit will display called user ID alternate and play short fluting. For communication the master unit must use voluntary call mode

B) Special user call

Press special calling button down, the green LED switch on. Then the master unit plays special music continuously, user ID display and corresponding LED on.

This indicates a normal user call. Just two operations and be done.

- 1) Press the special calling button down again, the green LED switch off, Then the master unit stop music, current time display and corresponding LED off. The user call stop.
- 2) Take the phone underhand up on the master unit any time, the normal calling button ring and the red LED switch on. The communication is set up between the master unit and special calling button. To put underhand down on the master unit or press down the special calling button again will disconnect the communication. The green LED and red LED will switch off on the special calling button.
- 3) There is no waiting status on the special user call.

C) Urgent user call

Press the urgent calling button down, the red LED switch on. Then the master unit plays alarm fluting continuously and must press the urgent calling button down again for stop calling. There is n communication feature between urgent calling button and master unit.

D) Master unit call

The master unit can call normal calling button or special calling button any time as usual telephone call. Take the phone underhand up, then

- 1) Enter user ID number 01 to 60 (96 when extend) can set up the communication with corresponding normal calling button or special calling button.
- 2) Enter '*' can stop all user's call.
- 3) Enter number 00 can realize broadcast feature.

E) Clock adjustment

There are three buttons on the faceplate of master unit. The left one is mode select, the middle one is decrease key and the right one is increase key.

F) Music style choice

There are 4 kinds of music can be selected by switch and the volume can also be adjusted.

5. Setting and Debugging

A) Setting calling button

Connect calling button and master unit, Press calling button down continuously until the red LED blinking. Enter wanted user ID on the telephone set attached the master unit. The red LED stops blinking on the

calling button and then complete the calling button setting when the red LED off.

Usually it is necessary to set the calling button before use and then the user ID will remain. Do not set again unless need to change the user ID.

B) Set/Reset special user

- 1) Take the phone underhand up on the master unit.
- 2) Enter user ID that wanted to set/reset calling button.
- 3) Repeat above step can set/reset other calling button.
- 4) Put the phone underhand down will complete the procedure.

C) Setting alarm lamp

Connect the alarm lamp and master unit. Press S1 button on the alarm lamp board, the LED will blink. Enter user ID from phone set attached the master unit.

The LED will off and the user ID of calling button (normal or special) stored in the alarm lamp. Press S2 button on the alarm lamp board will store user ID of the urgent calling button.

There are 16 user ID can be stored. Press S1/S2 button on the alarm lamp board and enter '*' from phone set. All user IDs will be cleared on the alarm lamp.

6. System Routing

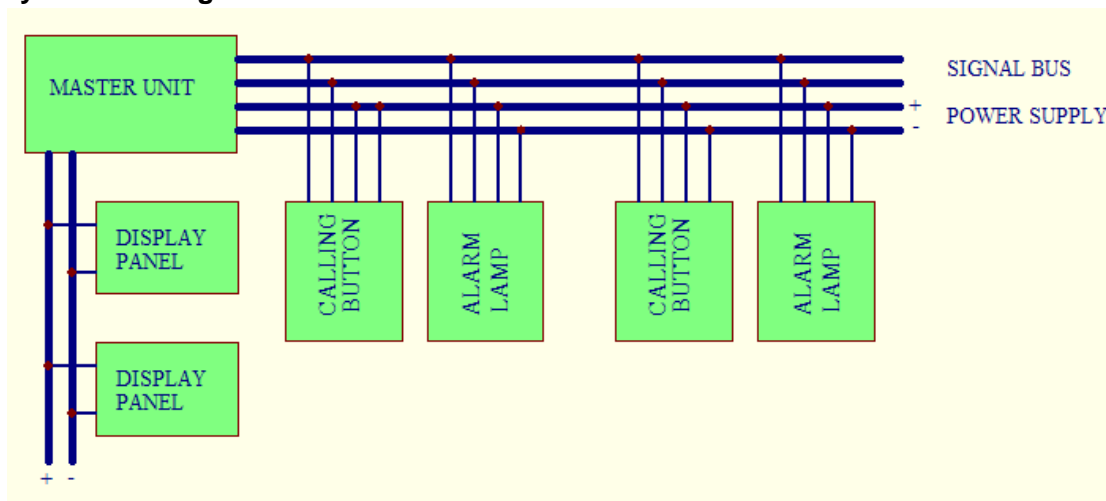

System routing (include alarm lamps, display panels and calling buttons)

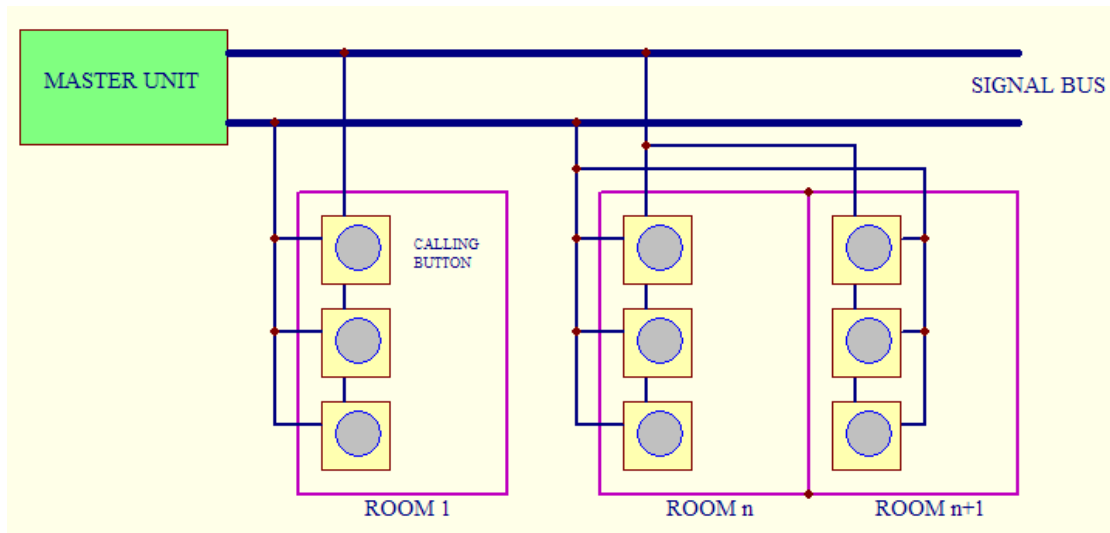

Routing between master unit and calling buttons

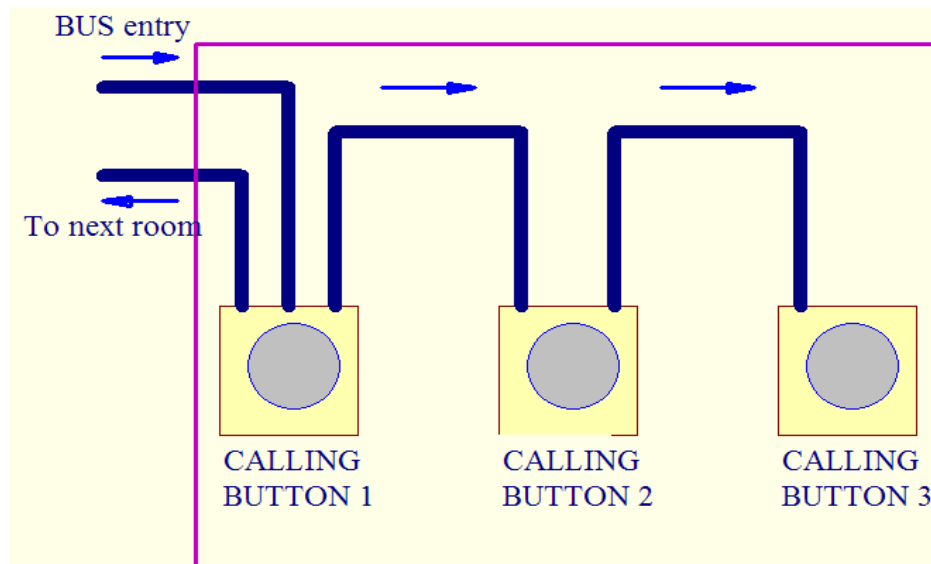

Room routing

Note:

- It is no necessary to concern the signal BUS polarity connected between master unit and calling buttons.
- The alarm lamps need other power supply connected master unit and alarm lamp.
- The display panel must use external power supply (+14V).
- Must rout the signal and power supply separately. The distance between both must greater than 50cm.

7. Troubleshooting

Problem	Reasons
The master unit display □□ and alarm when power on	The signal BUS short
Call failure	Disconnection between signal BUS, duplicate user ID, one or more calling button(s) failure
Display panel no response	Disconnection between master unit and display panel



Display panel can not on	External power supply (+14V) failure
--------------------------	--------------------------------------

8. Notice item

- The microphone must separate from speaker at least 50cm when communicate
- Must shut down the system when thunder.

9. Contact

Name : SHANGHAI KINGBELL ELECTRONIC CO., LTD

Address : 525 Fa Hua Zhen road, Shanghai,China

Telephone : 021-62813272, 021-62812560, 021-62818217

Fax: 021-62817095

Website: www.kingbell.com.cn

Mailbox: snow@kingbell.net